

BERNHARDT | design + **PLANK**



CATALOG 2023

BERNHARDT | design + **PLANK**

Bernhardt Design + Plank is a long-term partnership between two design focused family owned companies, one in America, the other in Italy, each with an aesthetic and heritage all their own. They share common values in the most important areas: the pursuit of quality, a deep appreciation for the value of design, and a commitment to innovation. Both brands have adapted to an ever-changing market through partnerships with the best designers of this era.

Bernhardt Design + Plank is the exclusive distributor for Plank's award- winning products in North America. An extensive Fast Track program offers two-week shipment on a wide array of seating and tables. In addition to products for interior spaces, Bernhardt Design + Plank features a broad collection of outdoor furniture.

The Plank collection is the fruit of intense research, where an innovative approach to form as well as technology underpins its design philosophy. Relations and close collaboration with designers are a key feature of our method, where frequent meetings and dialogue lead to the identification of a final product.



Plank Headquarters, Ora, Italy

A passion for research transforms Plank products from ideas and intuitions into furniture. When the highest quality of form is combined with that of technology.

Products

Chairs / Armchairs

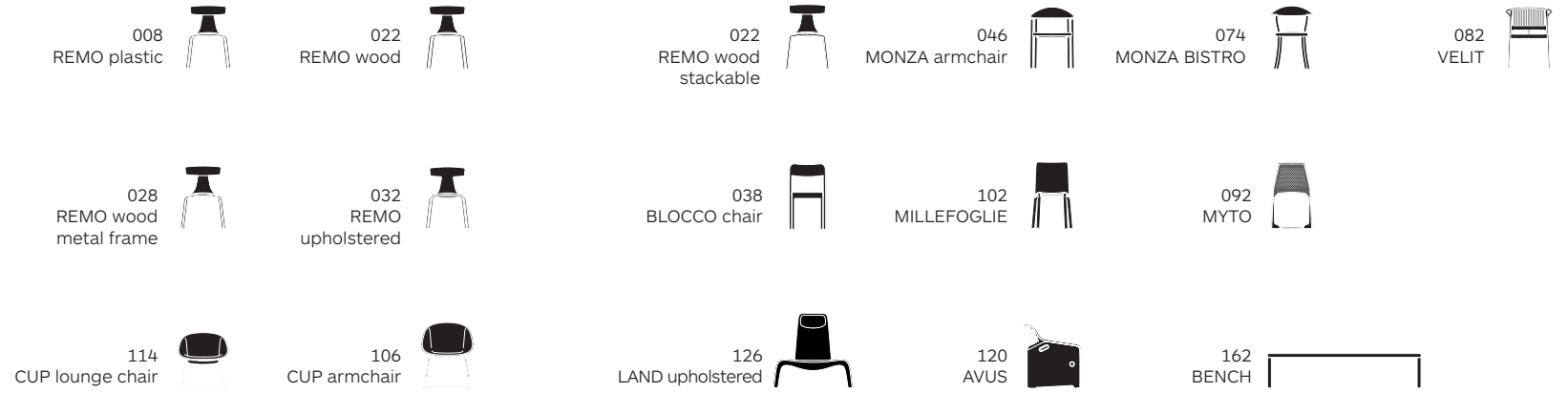

Stools



Tables

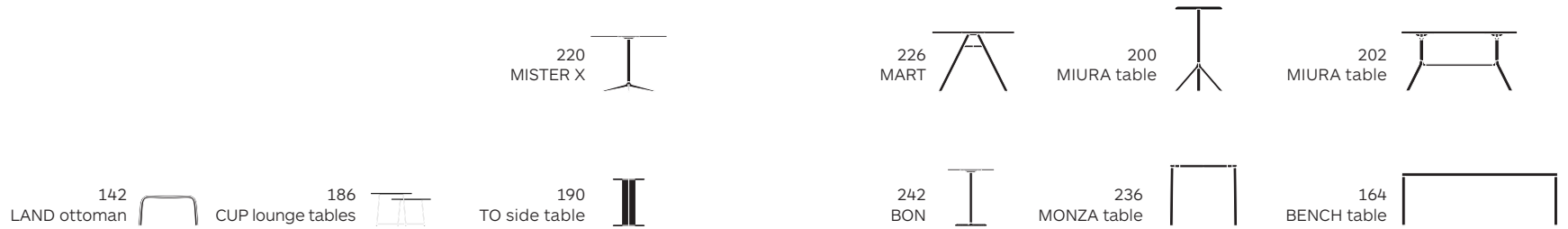

Outdoors

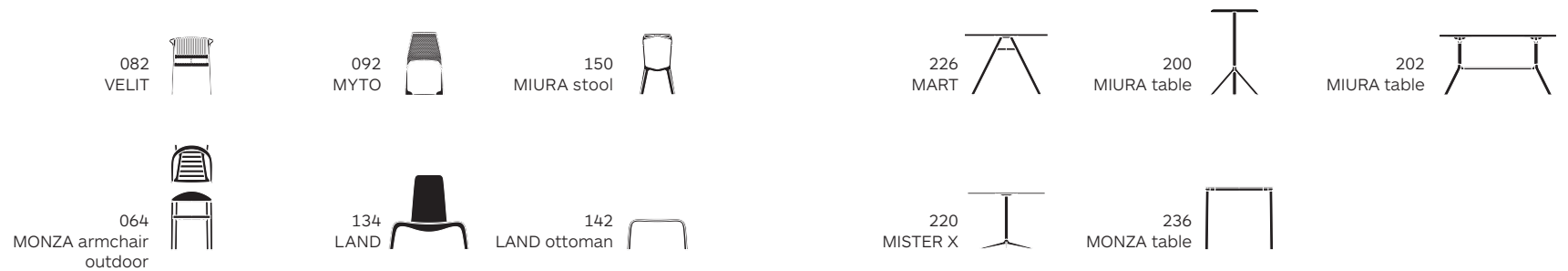

REMO

plastic chair stackable

Konstantin Grcic

Mod. 1417-20

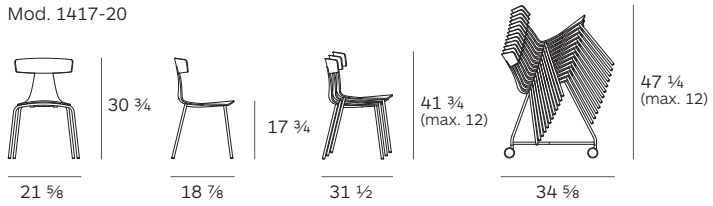

Polypropylene seat shell in the colors black, white, basalt grey, signal grey, green blue, yellow grey, avion blue, fern green, oxide red, pastel green, coral red, sulfur yellow. Metal frame in chrome or zinc coated/powder coated (outdoor) matched to the shell colors. Optional cushion in fabric or leather. Stackable.

Plastic finishes
Polypropylene



Frame

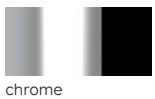

Cushion finishes

Leather p. 250
Alternate leather p. 252
Fabric p. 253















REMO wood chair

Konstantin Grcic

Mod. 1415-10

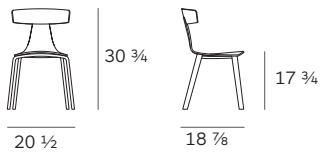

Mod. 1415-20
stackable

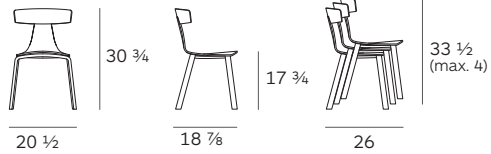

Plywood chair in natural finished ash or stained in the colors chalk, walnut, grey, black. Optional cushion in fabric or leather. Available as chair and stacking chair.

Cushion finishes

Leather p. 250

Alternate leather p. 252

Fabric p. 253

Wooden finishes

Ash

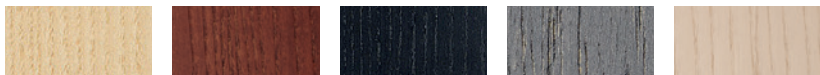

natural

walnut

black

grey

chalk







REMO

wood chair / metal frame

Konstantin Grcic

Mod. 1416-20

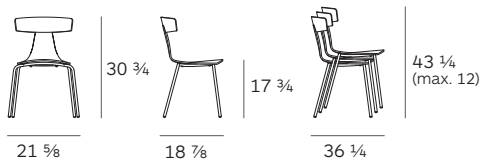

Plywood shell made of natural finished ash or colored with a matte open grain in white, grey, black, or yellow. Metal frame is matched to shell color. Optional cushion in fabric or leather.

Cushion finishes

Leather p. 250
Alternate leather p. 252
Fabric p. 253

Wooden finishes
Ash



Frame





REMO upholstered chair

Konstantin Grcic

Mod. 1418-20

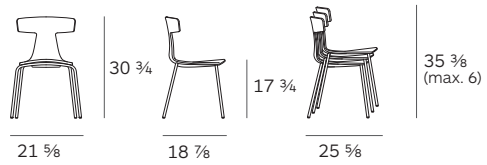

Fully upholstered shell with core in recycled polipropilene covered in various fabrics. Metal frame black powder-coated. Stackable.

Upholstery finishes

Fabric p. 253

Frame



black







BLOCCO chair

Naoto Fukasawa

Mod. 1475-20

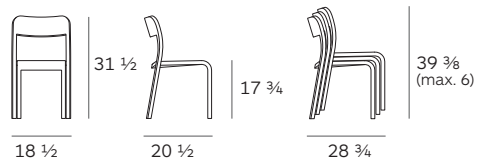

Chair. Ash wooden structure natural lacquered, black stained lacquered or colored with a matte open grain in grey, white and blue. Stackable.

Wooden finishes

Ash



natural

black

grey

white

blue









MONZA armchair

Konstantin Grcic

Mod. 1209-40

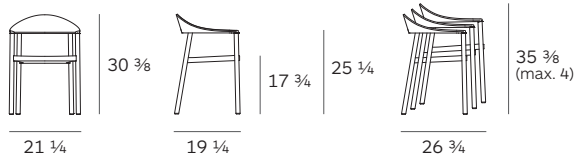

Armchair stackable, structure in ash, oak or walnut natural lacquered or ash black or white stained- lacquered. Backrest in polypropylene in the colors black, white, traffic red, wine red, light blue, yellow green, cafe latte, caramel, terra brown. Optional cushion in fabric or leather. Available with linking device.

Wooden finishes
Ash



Canaletto Walnut



Oak



Backrest colors
Polypropylene

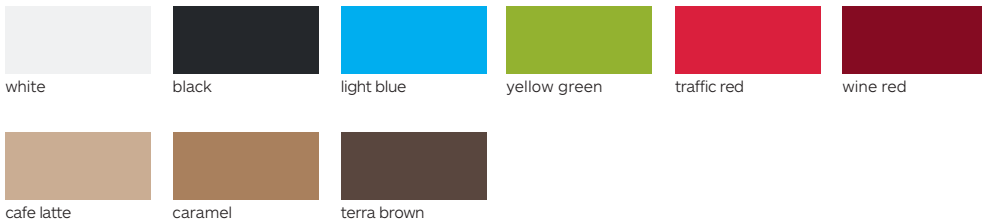

Cushion finishes

Leather p. 250
Alternate leather p. 252
Fabric p. 253











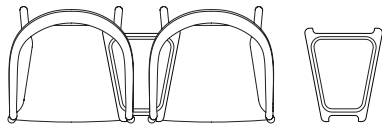







MONZA

armchair outdoor

Konstantin Grcic

Mod. 1209-40

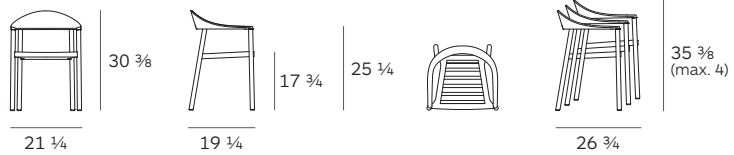

Armchair stackable, iroko wooden structure, oil treated. Backrest in polypropylene in the colors black, white, traffic red, wine red, light blue, yellow green, cafe latte, caramel, terra brown. Indoor and outdoor use.

Wooden finishes
Iroko



natural

Backrest colors
Polypropylene



white black light blue yellow green traffic red wine red



cafe latte caramel terra brown

Cushion finishes
Fabric p. 253







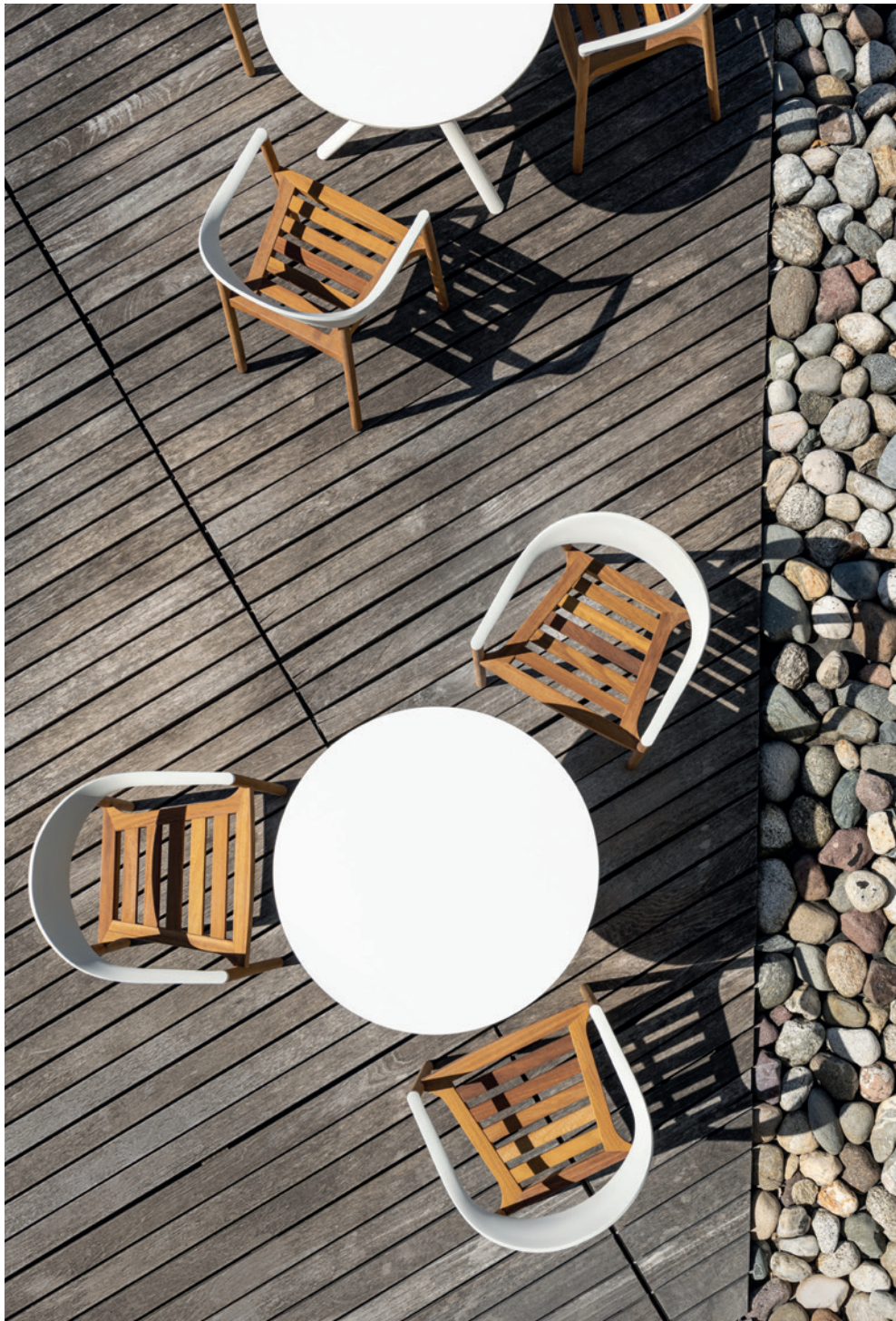



MONZA BISTRO chair

Konstantin Grcic

Mod. 1212-20

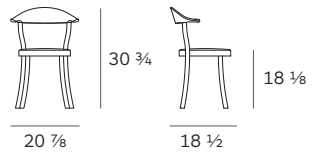

Chair, beech wooden structure natural lacquered or black stained-lacquered. Backrest in polypropylene in the colors black, white, cafe latte, caramel, terra brown. Seat made of flexible integral skin polyurethane foam matched to the backrest colors.

Wooden finishes

Beech



natural



black

Seat

Integral skin polyurethane foam

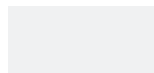

white



black



cafe latte



caramel



terra brown

Backrest colors

Polypropylene

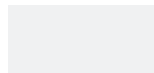

white



black



cafe latte



caramel



terra brown









VELIT chair

Björn Dahlström

Mod. 1800-40

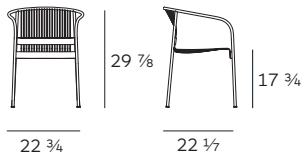

Mod. 1800-99

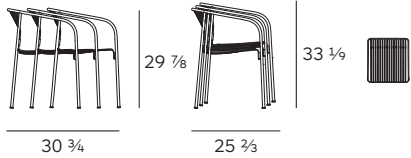

Metal frame in tubular steel, seat and backrest in metal-wire powder coated in the colors ocean blue, moss green, olive green, concrete grey, white, black. Removable self-skinning integral polyurethane cushion in frame colors (except white). Plastic glides. Indoor and outdoor use.

Frame



ocean blue

olive green

moss green

oxide red

concrete grey

white



black

Cushion

Integral skin polyurethane foam



ocean blue

olive green

moss green

oxide red

concrete grey

light grey



black











MYTO chair

Konstantin Grcic

Mod. 1207-20

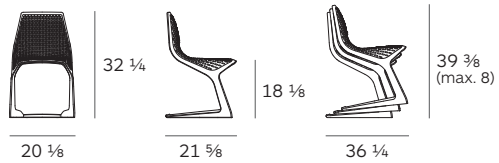

Cantilever chair entirely made of plastic in black, white, traffic red, pure orange, yellow green, or light blue. Stackable, for indoor and outdoor use, recyclable.

Plastic finishes
Polypropylene











MILLEFOGLIE chair

Biagio Cisotti + Sandra Laube

Mod. 1620-20

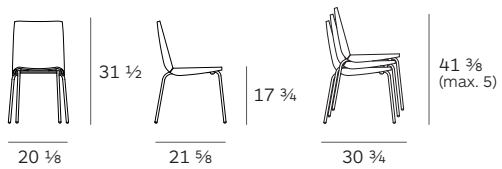

Stackable chair, chrome plated metal frame, seat and back in molded plywood veneered with zebrano.

Wooden finish



zebrano

Frame



chrome





CUP armchair

Konstantin Grcic

Mod. 1950-12

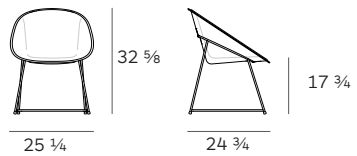

Armchair. Seat shell in plastic in the colors black or white. Upholstery in various textiles and colors combined with the seat shell. Metal frame in chrome or black powder coated.

Seat shell colors
ABS



Frame



Upholstery finishes
Leather p. 250
Alternate leather p. 252
Fabric p. 253









CUP loung chair

Konstantin Grcic

Mod. 1960-12

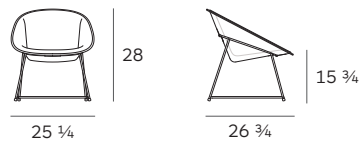

Lounge chair. Seat shell in plastic in the colors black and white. Upholstery in various textiles and colors combined with the seat shell. Metal frame in chrome or black powder coated.

Seat shell colors
ABS



Frame



Upholstery finishes

Leather p. 250
Alternate leather p. 252
Fabric p. 253







AVUS club chair

Konstantin Grcic

Mod. 1920-12

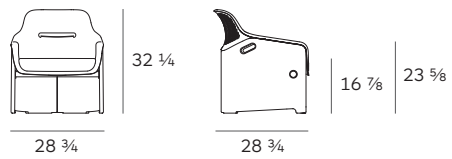

Lounge chair, base and seat shell in plastic, upholstery in polyurethane foam, covering in leather.

Upholstery finishes
Leather p. 250

Backrest
ABS gloss

Base
ABS matte



black



pearl mouse grey



black



pearl mouse grey





MUSEION

Collection

Kids



LAND

lounge chair upholstered

Naoto Fukasawa

Mod. 1150-00

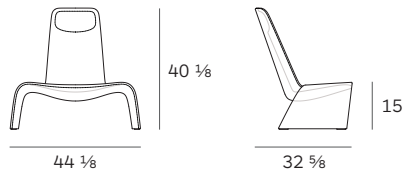

Lounge chair. Injected polyurethane foam covered with textile, synthetic leather, leather.

Upholstery finishes
Leather p. 250
Alternate leather p. 252
Fabric p. 253









LAND loung chair

Naoto Fukasawa

Mod. 1100-00

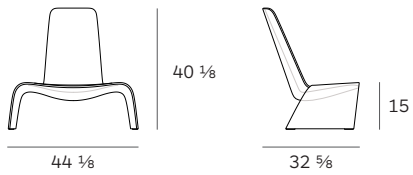

Lounge chair entirely made of polyethylene (rotational molding) in the colors black, white, basalt grey, signal grey, traffic red, and yellow green. For indoor and outdoor use.

Plastic finishes
Polyethylene



black

white

basalt grey

signal grey

traffic red

yellow green





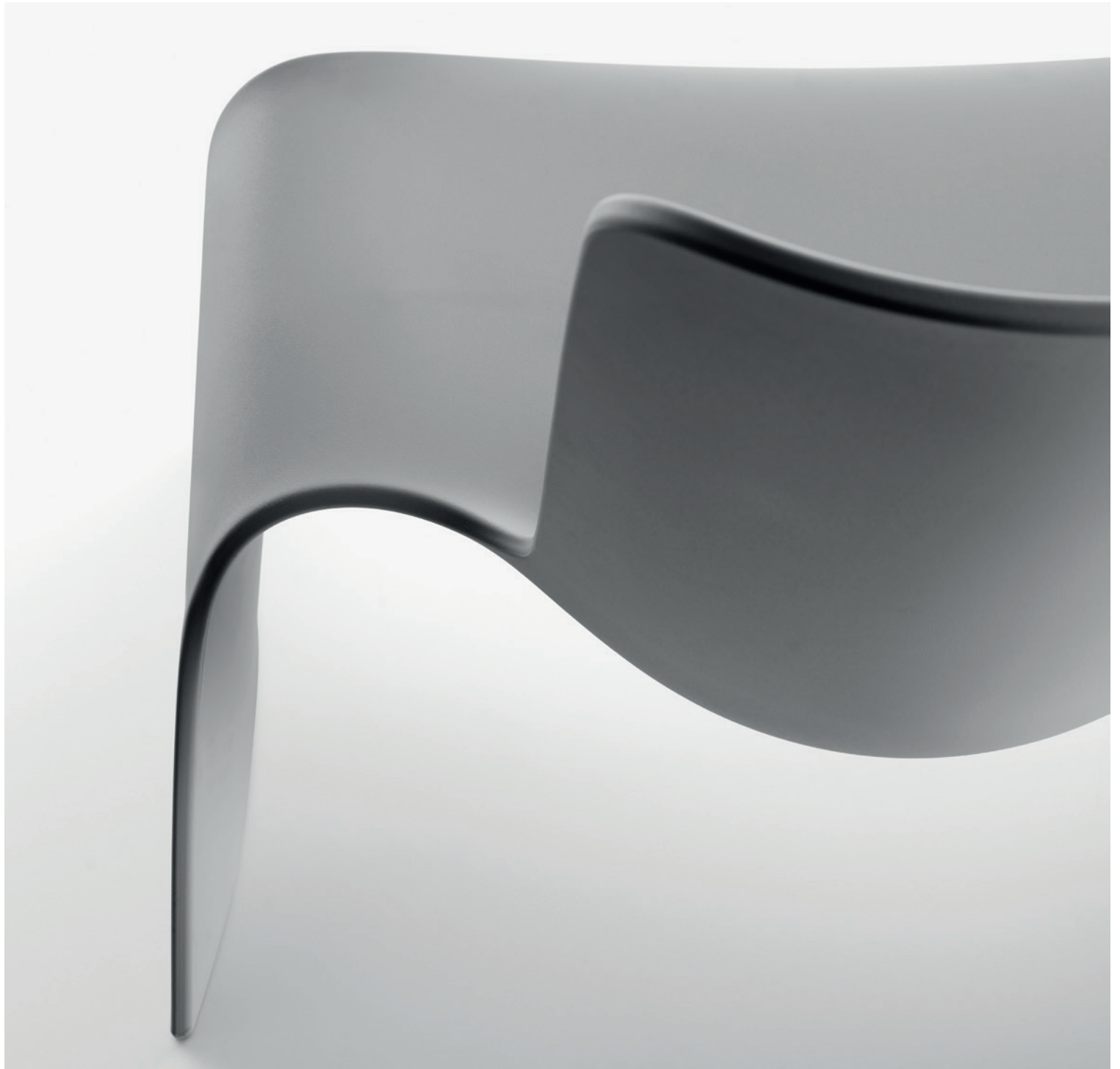



LAND ottoman

Naoto Fukasawa

Mod. 1050-00



Ottoman entirely made of polyethylene (rotational molding) in the colors black, white, basalt grey, signal grey, traffic red, and yellow green. For indoor and outdoor use.

Plastic finishes
Polyethylene









MIURA stool

Konstantin Grcic

Mod. 8200-00

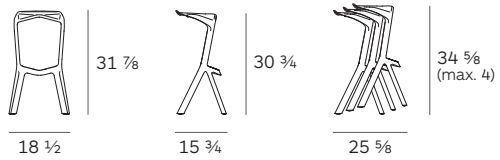

Stool made of polypropylene available in black, white, pure orange, traffic red, wine red, light blue, yellow green. Stackable. Indoor and outdoor use, recyclable.

Plastic finishes
Polypropylene

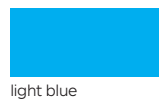





BLOCCO stool

Naoto Fukasawa

Mod. 8500-60

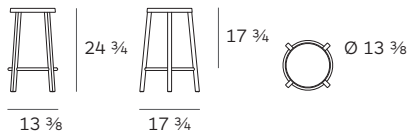

Mod. 8500-00

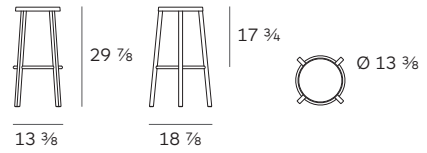

Bar or counter stool. Ash wooden structure natural lacquered, black stained lacquered or colored with a matte open grain in grey, white or blue. Footrest in satin or polished aluminum.

Wooden finishes
Ash

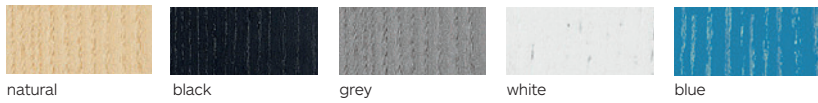

Footrest
Aluminum

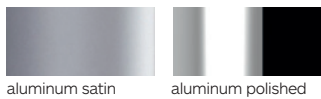





BENCH

Konstantin Grcic

Mod. 0628-01

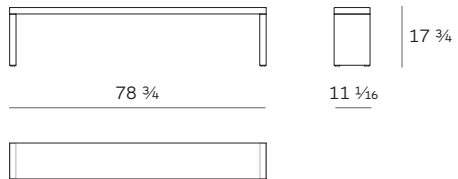

Seat and sides in solid wood, spruce oiled. Wood elements connected by a quick assembly system. Glides in plastic or felt.

Wooden finishes
Spruce



natural

Glides



Plastic glides



Felt glides



BENCH table

Konstantin Grcic

Mod. 0660-01

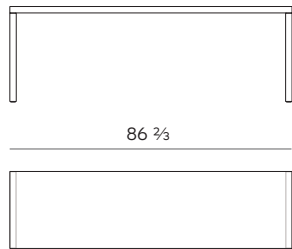

Mod. 0661-01

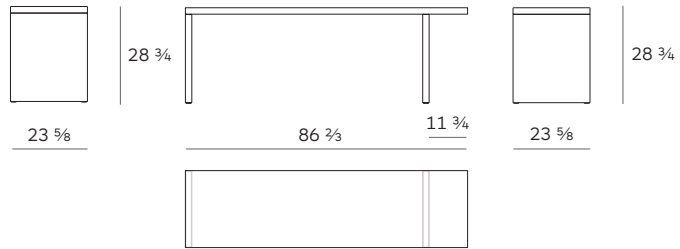

Mod. 0662-01

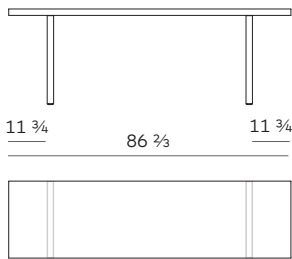

Mod. 0682-01

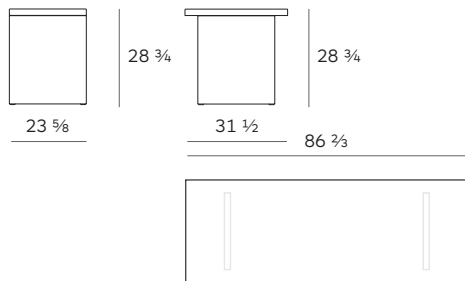

Table top and sides in solid wood, spruce oiled. Wood elements connected by a quick assembly system. Glides in plastic or felt.

Wooden finishes
Spruce



natural

Glides



Plastic glides



Felt glides























CUP tables

Konstantin Grcic

Mod. 9100-51

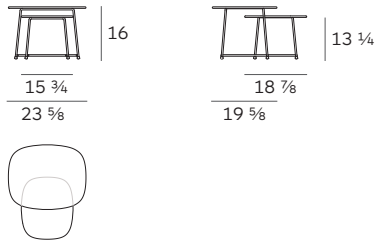

Lounge tables. Metal structure in chrome or black powder coated. Table top in high pressure laminate (HPL) in various finishings and colors.

Table top
HPL - FENIX NTM®



nero ingo (black) bianco kos (white)

HPL - FunderMax FH

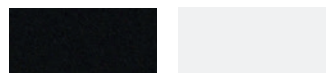

black white

HPL - Marmor



nero marquinia (black) bianco carrara (white)

Frame



black chrome





TO side table

Naoto Fukasawa

Mod. 9050-51

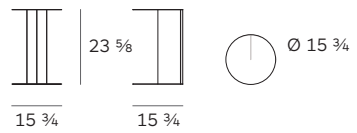

Base, column and table top made of sheet steel, powder-coated in the colors agate grey, quartz grey, black red, black. Glides in felt.

Frame



Glides



Felt glides











MIURA table

Konstantin Grcic

Mod. 9553-51

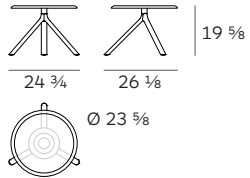

Mod. 9553-01

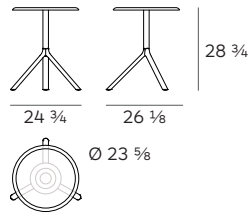

Mod. 9553-71

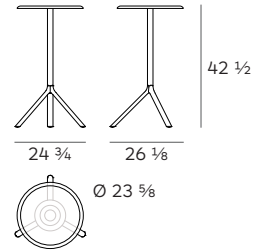

Mod. 9590-51 (Ø 27 1/2)

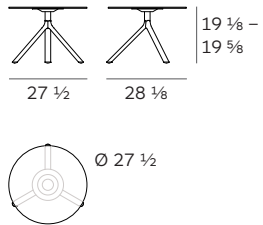

Mod. 9590-01 (Ø 27 1/2)
Mod. 9591-01 (Ø 31 1/2)
Mod. 9592-01 (Ø 35 3/8)

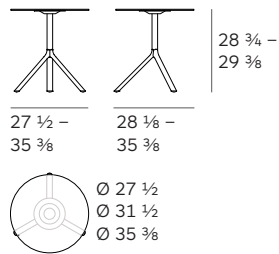

Mod. 9590-71 (Ø 27 1/2)
Mod. 9591-71 (Ø 31 1/2)

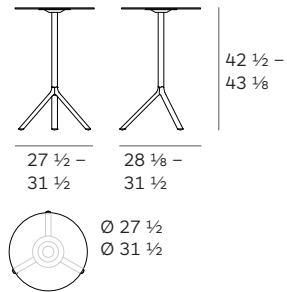

Mod. 9580-51
(27 1/2 x 27 1/2)

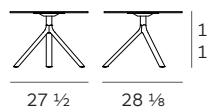

Mod. 9580-01
(27 1/2 x 27 1/2)

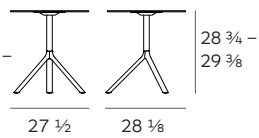

Mod. 9580-71
(27 1/2 x 27 1/2)

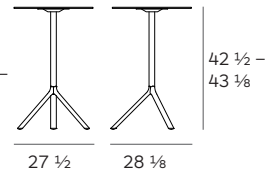

Mod. 9555-01 (Ø 39 3/8)
Mod. 9556-01 (Ø 43 1/4)

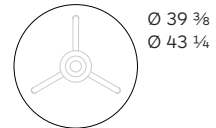
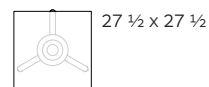
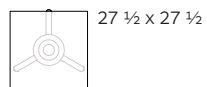
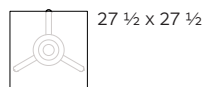
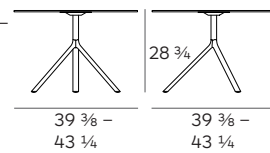

Mod. 9586-01

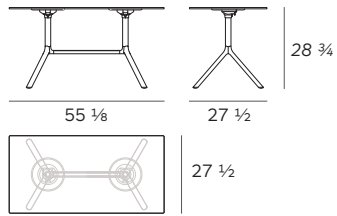

Mod. 9586-71

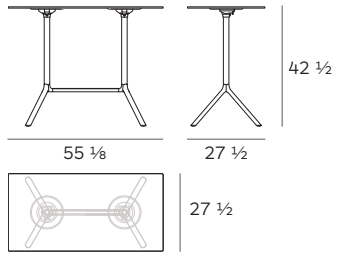

Mod. 9587-01

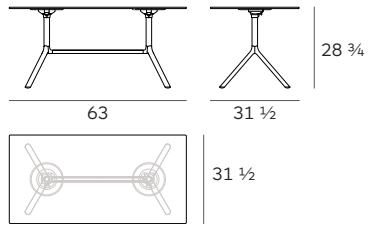

Mod. 9587-71

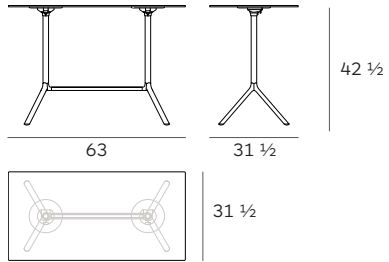

Table system, structure in powder coated aluminium, top in powder coated aluminium, top in powder coated metal, MDF or HPL Full colour in black and white, (metal tops also in red). With folding table top. Gliders in plastic. For indoor and outdoor use.

Table top

HPL - FunderMax FH
HPL - FENIX NTM® (nero ingo, indoor)



MDF (Ø27 1/2", Ø31 1/2", 27 1/2x27 1/2")
indoor



Metal table top (Mod. 9553)
powder coated

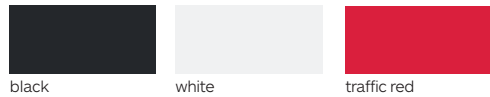

Frame
Aluminum
powder coated

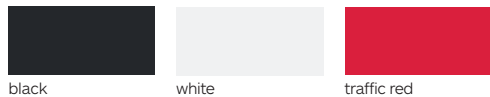

(Mod. 9553)



















MISTER X table

Biagio Cisotti + Sandra Laube

Mod. 9505-51 (Ø 23 5/8")
Mod. 9506-51 (Ø 27 1/2")
Mod. 9507-51 (Ø 31 1/2")

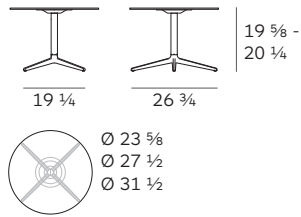

Mod. 9505-01 (Ø 23 5/8")
Mod. 9506-01 (Ø 27 1/2")
Mod. 9507-01 (Ø 31 1/2")

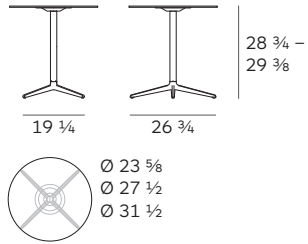

Mod. 9505-71 (Ø 23 5/8")
Mod. 9506-71 (Ø 27 1/2")
Mod. 9507-71 (Ø 31 1/2")

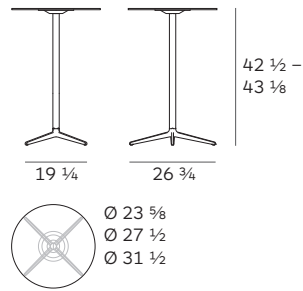

Mod. 9510-51 (27 1/2" x 27 1/2")
Mod. 9511-51 (31 1/2" x 31 1/2")

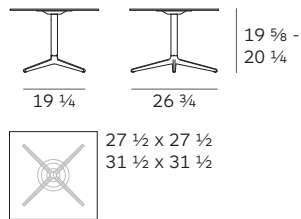

Mod. 9510-01 (27 1/2" x 27 1/2")
Mod. 9511-01 (31 1/2" x 31 1/2")

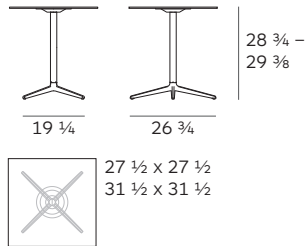

Mod. 9510-71 (27 1/2" x 27 1/2")
Mod. 9511-71 (31 1/2" x 31 1/2")

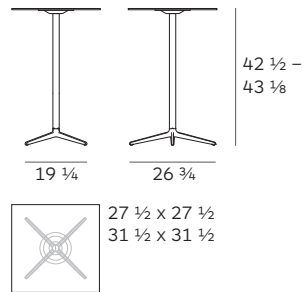

Table. Four star cast iron base
black or white powder coated.
Table top in high pressure laminate
(HPL) Full Color or in MDF powder
coated in black or white. Adjustable
glides. For indoor and outdoor use.

Table top
HPL - FunderMax FH
HPL - FENIX NTM® (nero ingo, indoor)



black white

MDF indoor (Ø27 1/2", Ø31 1/2",
27 1/2" x 27 1/2", 31 1/2" x 31 1/2")



black white

Table base
Cast iron
Powder coated



black white







MART table

P. lab

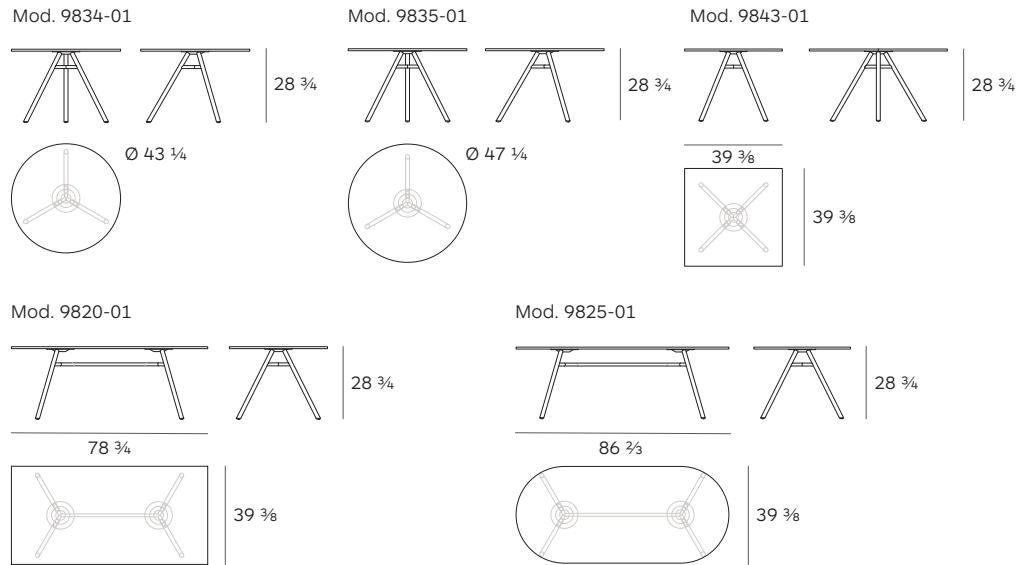

Table System. Structure in powder coated metal in the colors black, white. Aluminum extrusion table legs with white or black powder coating or aluminum wrapped natural ash veneer. Table top in white or black high pressure laminate (HPL). Gliders in plastic. For indoor and outdoor (powder-coated leg version only) use.

Table top
HPL - FunderMax FH
HPL - FENIX NTM® (nero ingo, indoor)



black white

Leg finishes
Aluminum extrusion
powder coated



black white

Wrapped ash veneer
(indoor)



natural

Structure
Metal
powder coated



black white











MONZA table

Konstantin Grcic

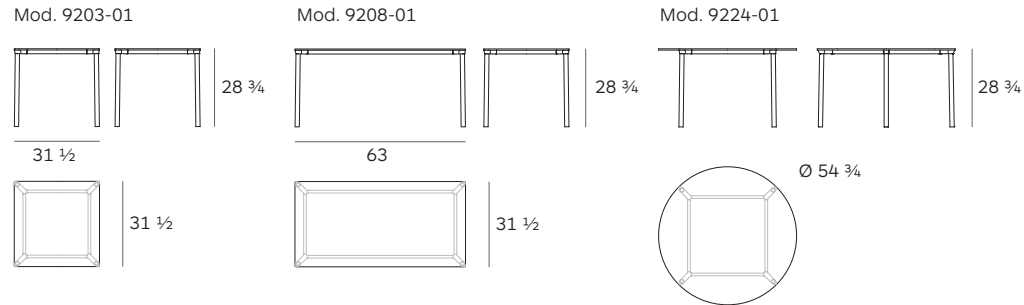

Table system, structure in aluminum white or black powder coated, legs in aluminum white or black powder coated or in ash natural lacquered. Table top in high pressure laminate (HPL) in the colors white or black. Adjustable glides. For indoor and outdoor (powder-coated leg version only) use.

Table top
HPL - FunderMax FH
HPL - FENIX NTM® (nero ingo, indoor)



Leg finishes
Aluminum extrusion
powder coated



Massive ash
indoor







BON table

Biagio Cisotti + Sandra Laube

Mod. 9380-51 (Ø23 5/8)
Mod. 9382-51 (Ø27 1/2)

Mod. 9380-01 (Ø23 5/8)
Mod. 9382-01 (Ø27 1/2)

Mod. 9380-71 (Ø23 5/8)
Mod. 9382-71 (Ø27 1/2)

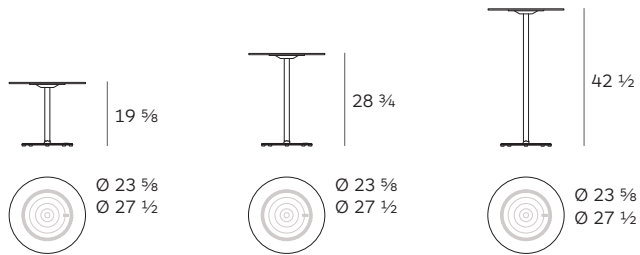

Table. Cast iron base and metal column powder coated in the colors black, white or grey aluminum.
Table top in high pressure laminate (HPL) Full Color in black or white.
Gliders in plastic.

Table top
HPL - FunderMax FH
HPL - FENIX NTM® (nero ingo)



black

white

Table base
Cast iron
powder coated



black

white

grey aluminium









Finishes
Leather
Dani Leather Florida

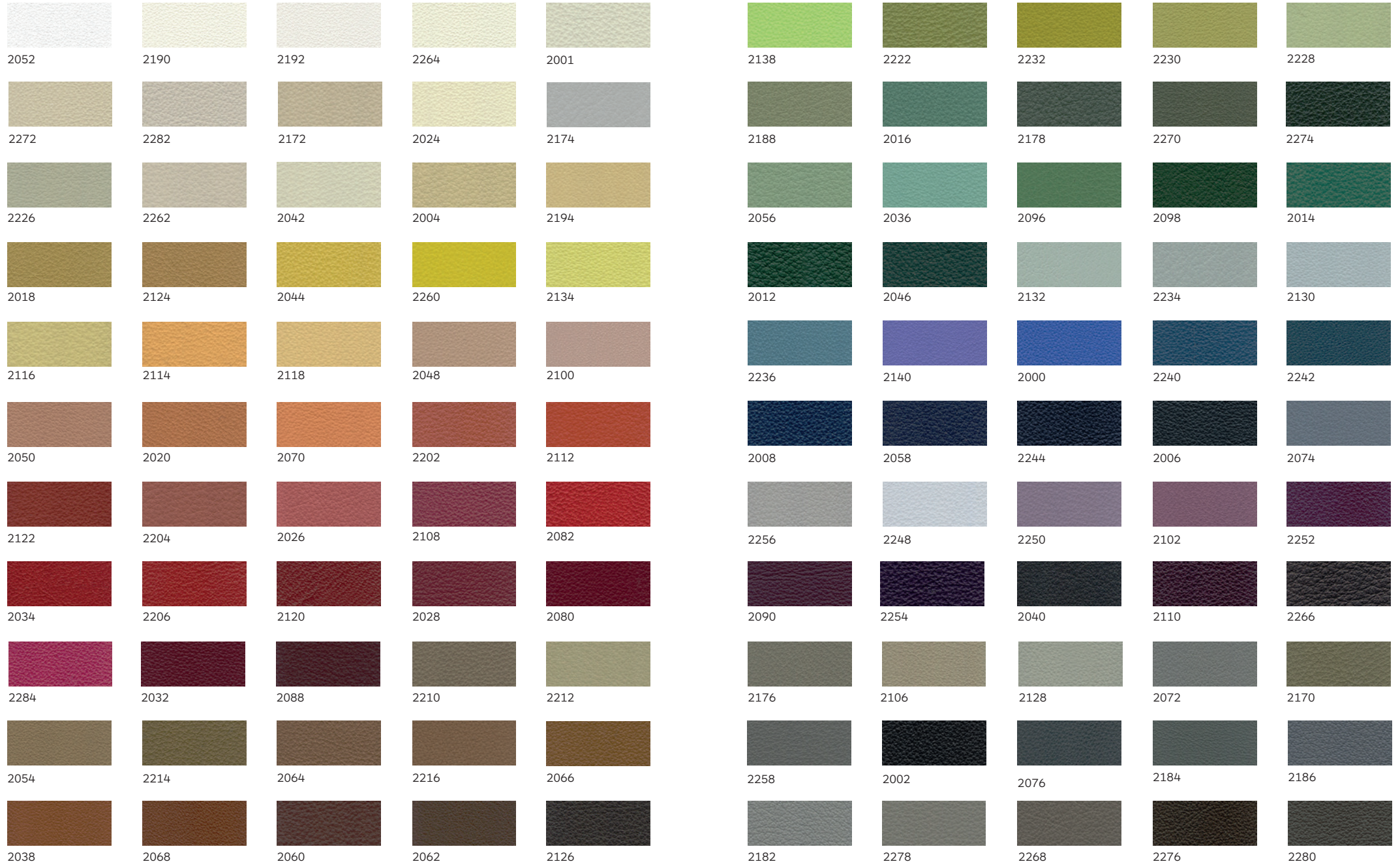

Finishes
Alternate leather
Continental skai® Toledo



Finishes
Fabric
Gabriel Swing

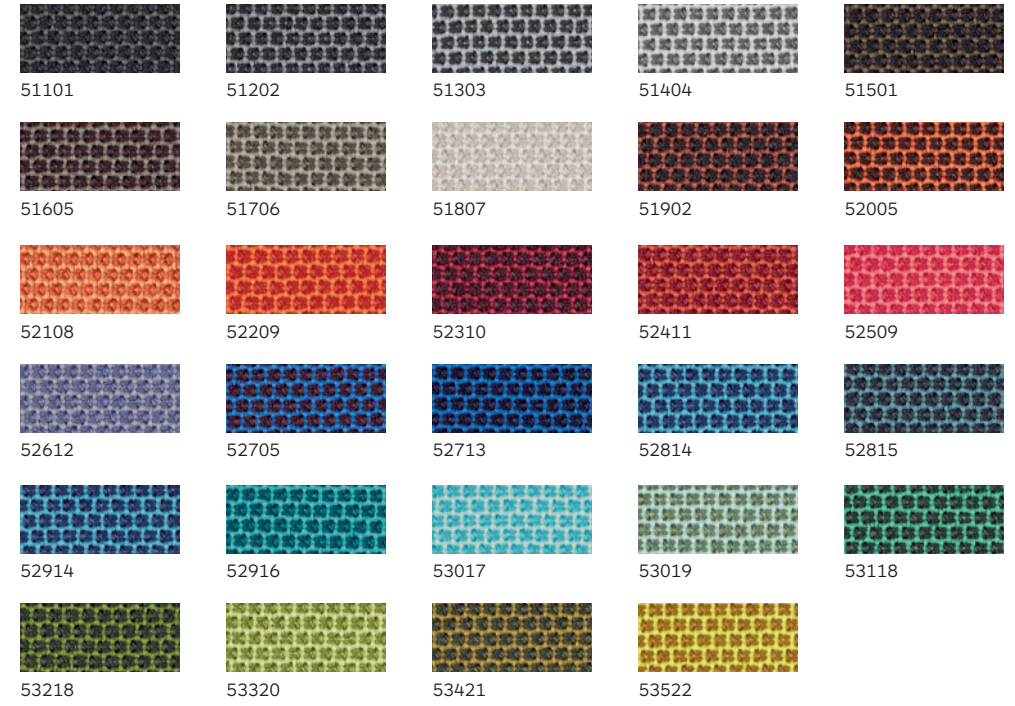

Finishes
Fabric
Gabriel Breeze Fusion

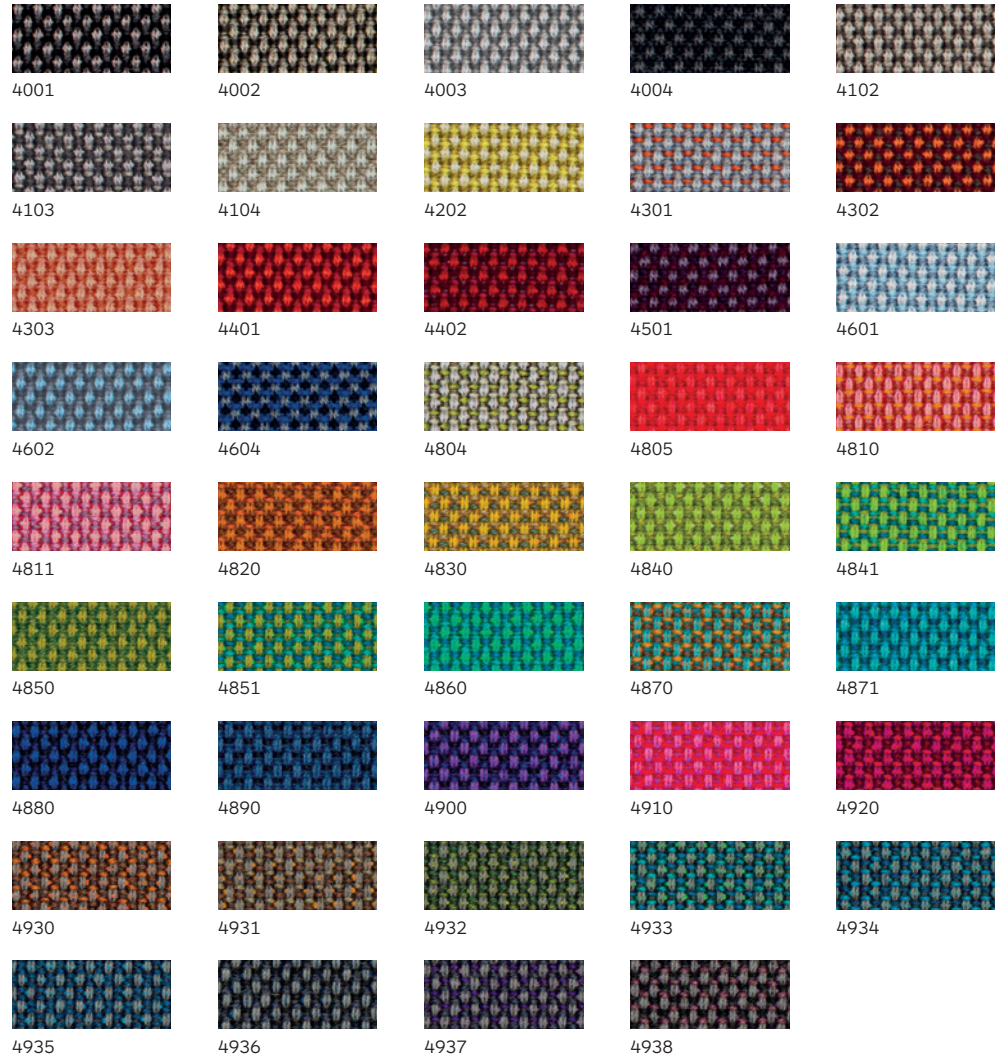

Finishes
Fabric
Kvadrat Tonus 4



Finishes
Fabric
Kvadrat Divina Melange 3

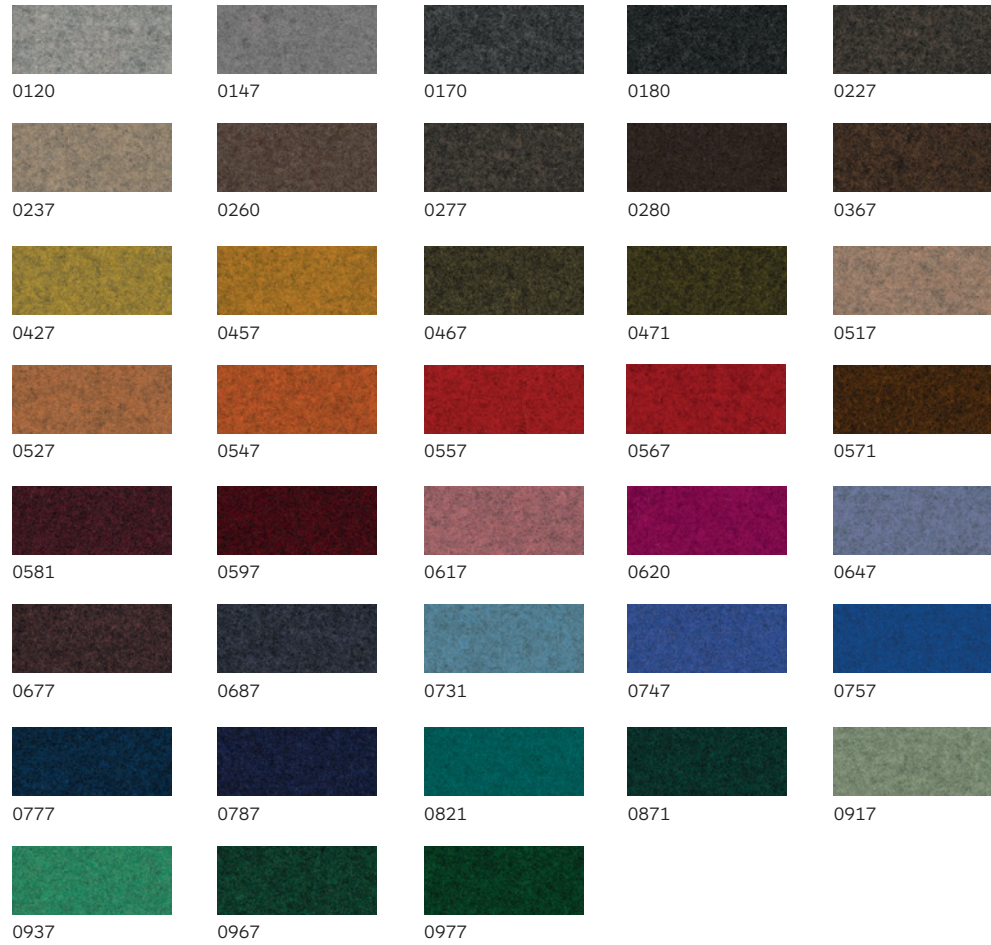

Finishes
Fabric
Abitex Vortice

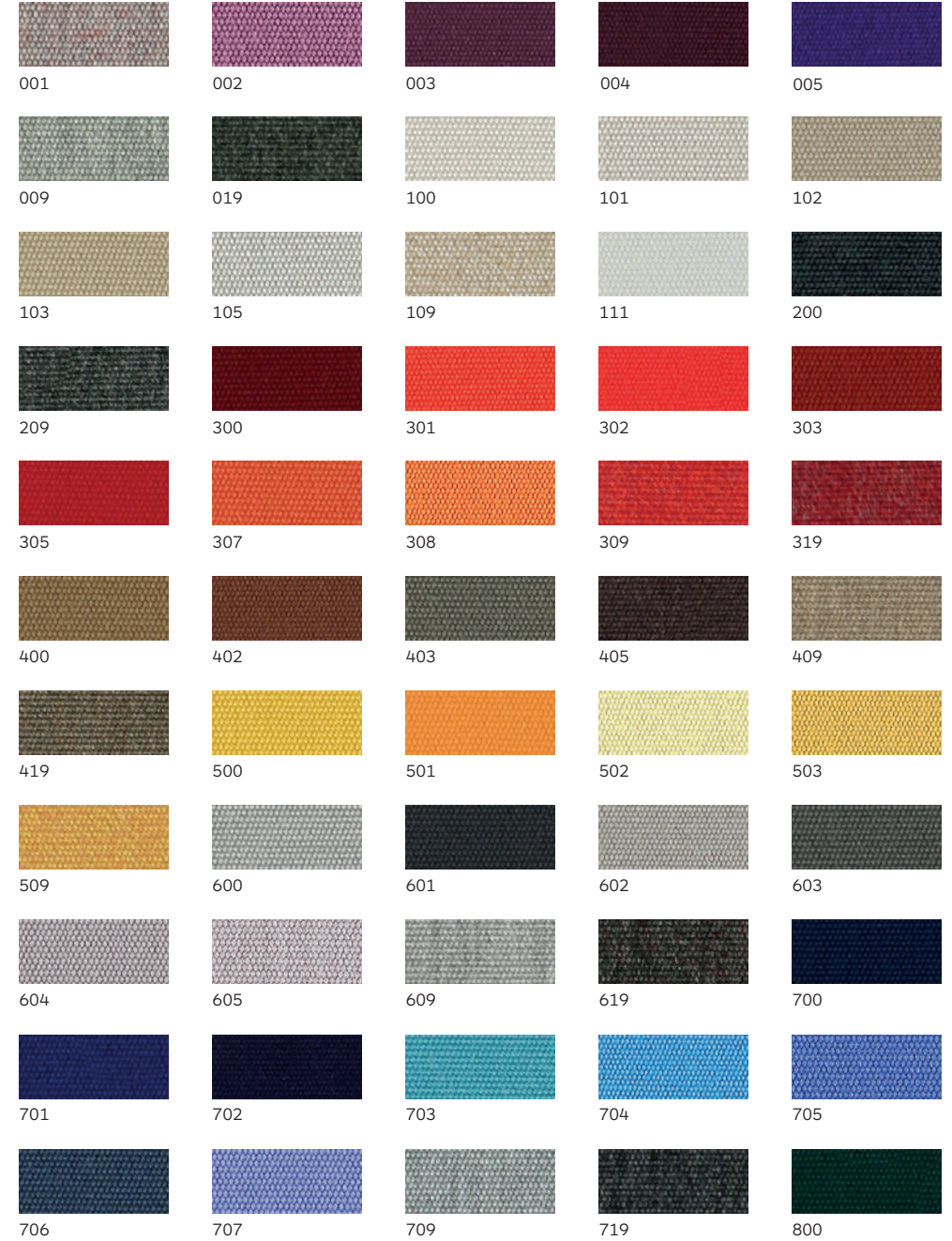



801



802



803



804



805



808



809



900



1000

Please be aware that the printed color shades (paper, PDF) can appear different from the real material colors.

Art Direction:
Biagio Cisotti

Graphic Design:
Sandra Laube

Product Photography:
Miro Zagnoli

Location Photography:
Luca Meneghel

Printed in Italy on environmentally friendly paper, May 2023.

Bernhardt Design + PLANK
bernhardtdesignplank.com
info@bernhardtdesignplank.com
1-877-BD-PLANK

Quality system according to ISO 9001
© 2023 Plank Srl - All Products International Deposit of Industrial Design



Bernhardt Design + PLANK
bernhardtdesignplank.com
info@bernhardtdesignplank.com
1-877-BD-PLANK